

REVISION HISTORY				
ZONE	REV	DESCRIPTION	DATE	APPROVED
SIDE PANELS	1	TEMPERED GLASSES	5/17/2017	P CH

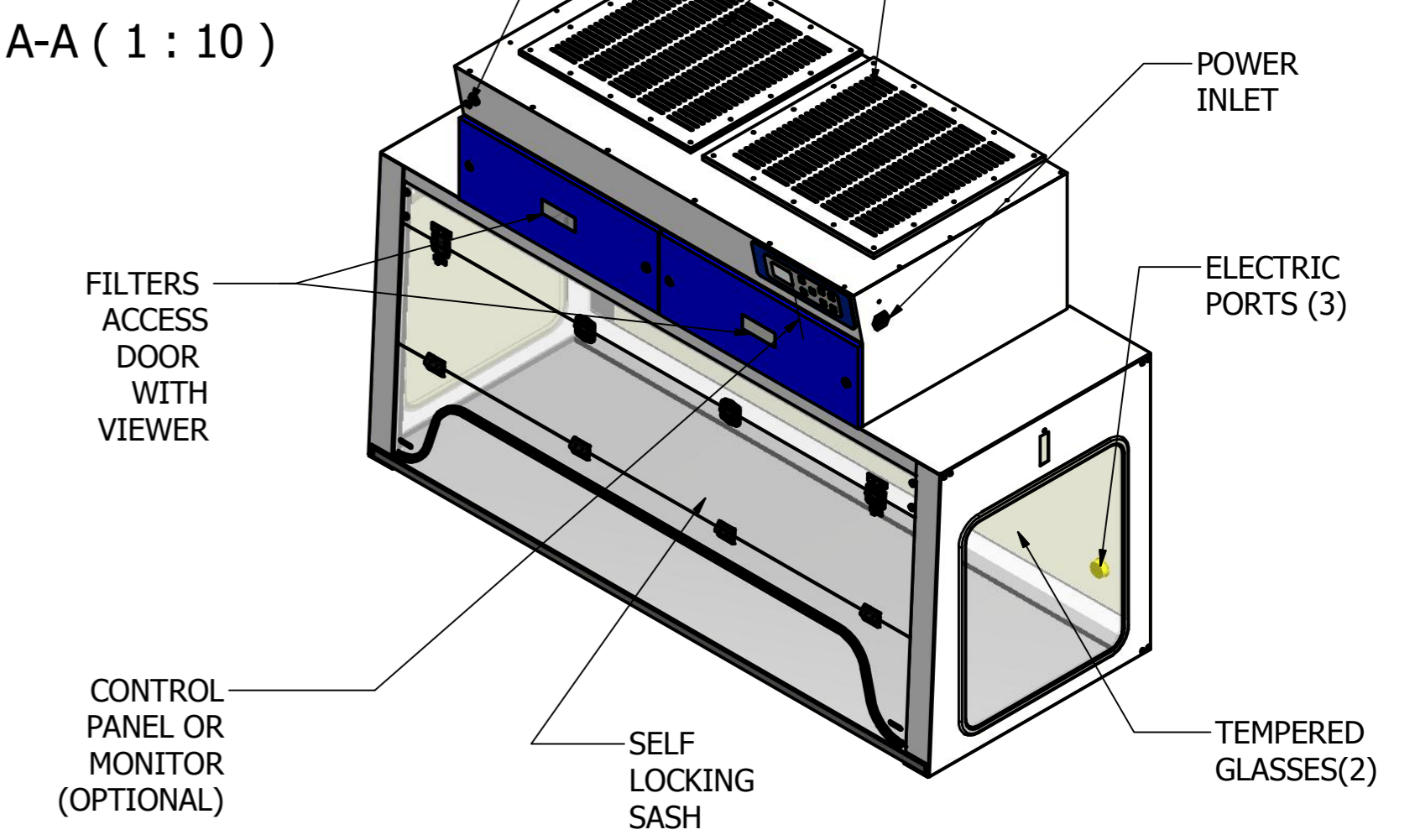
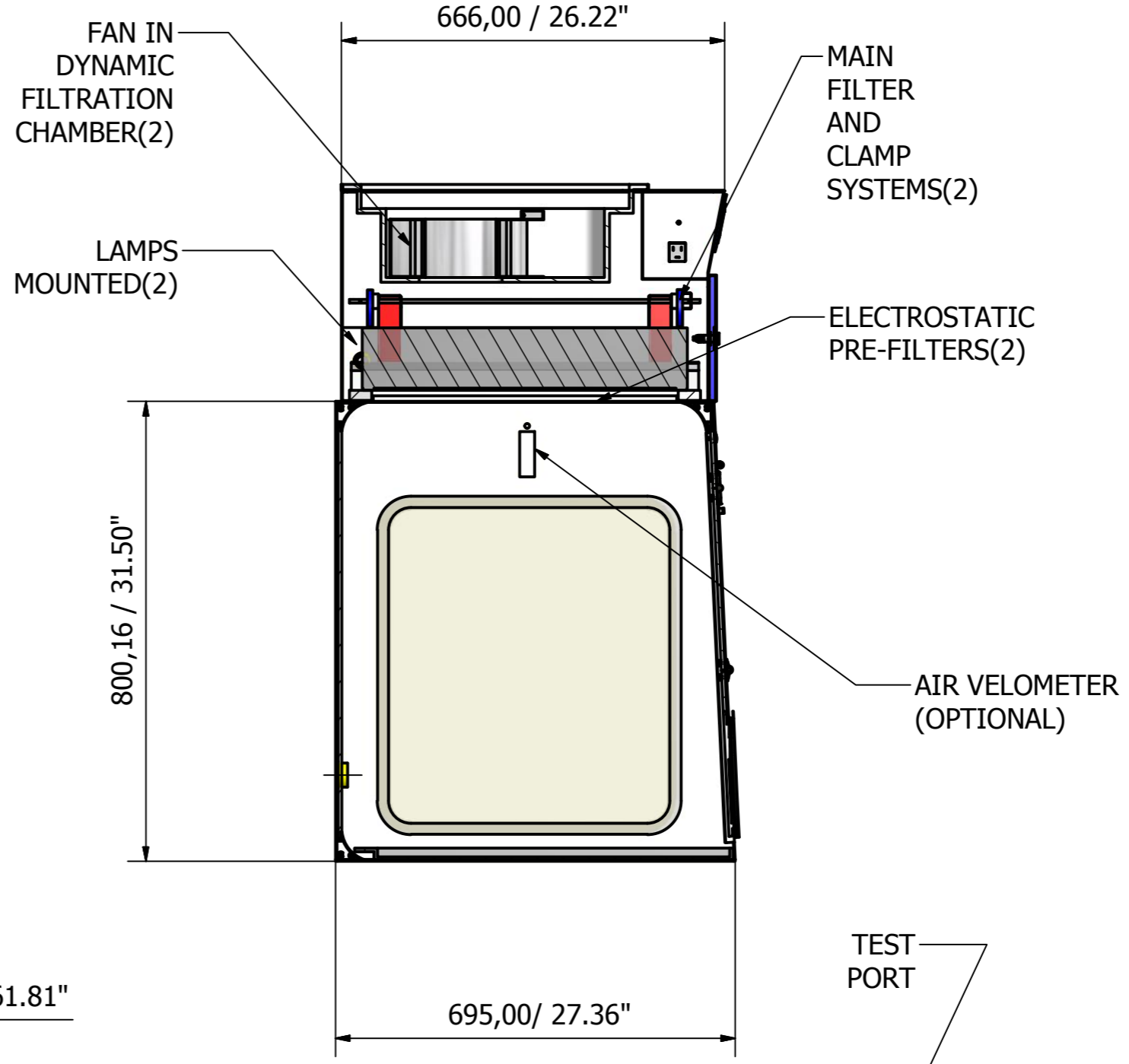
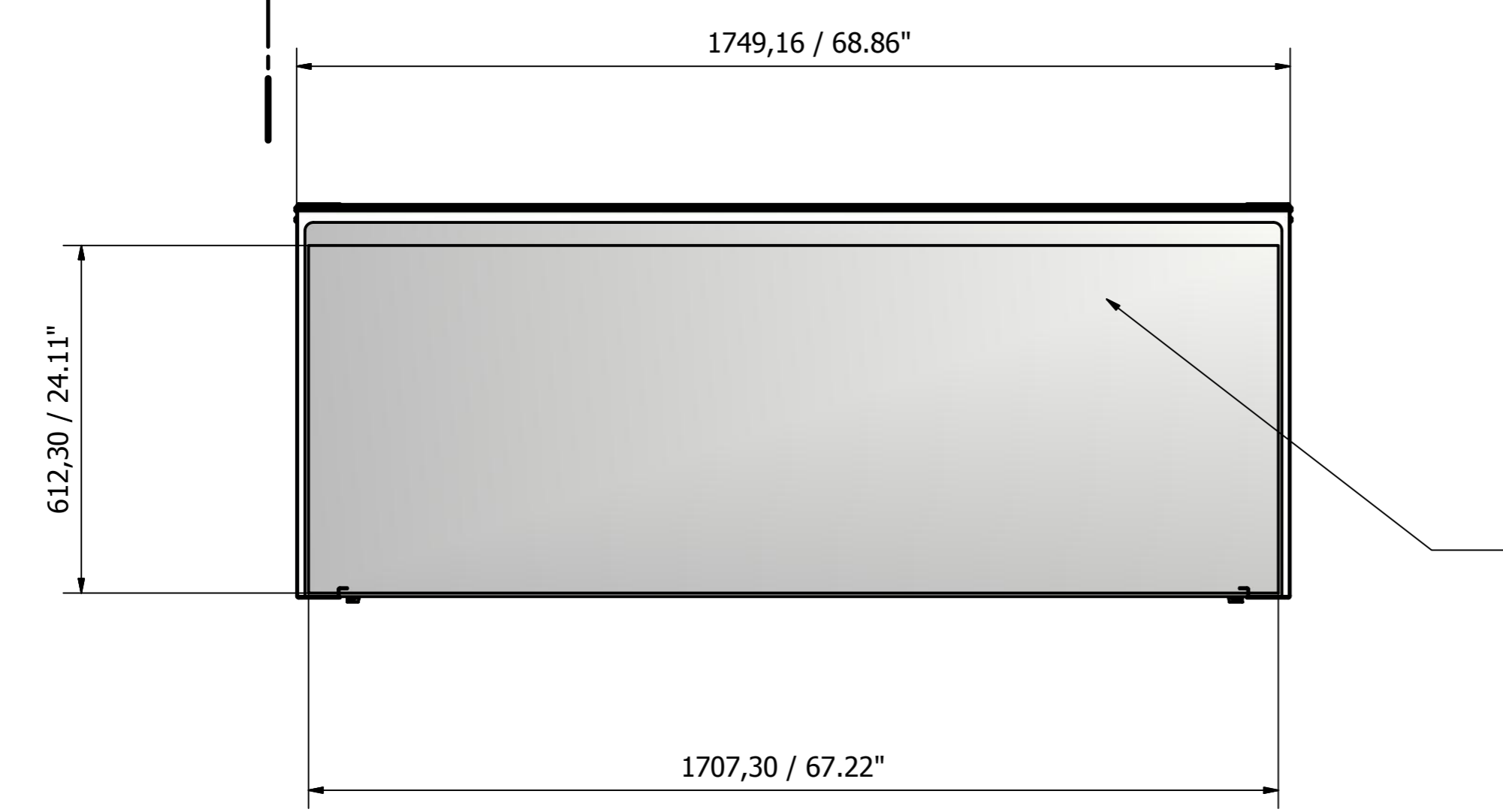
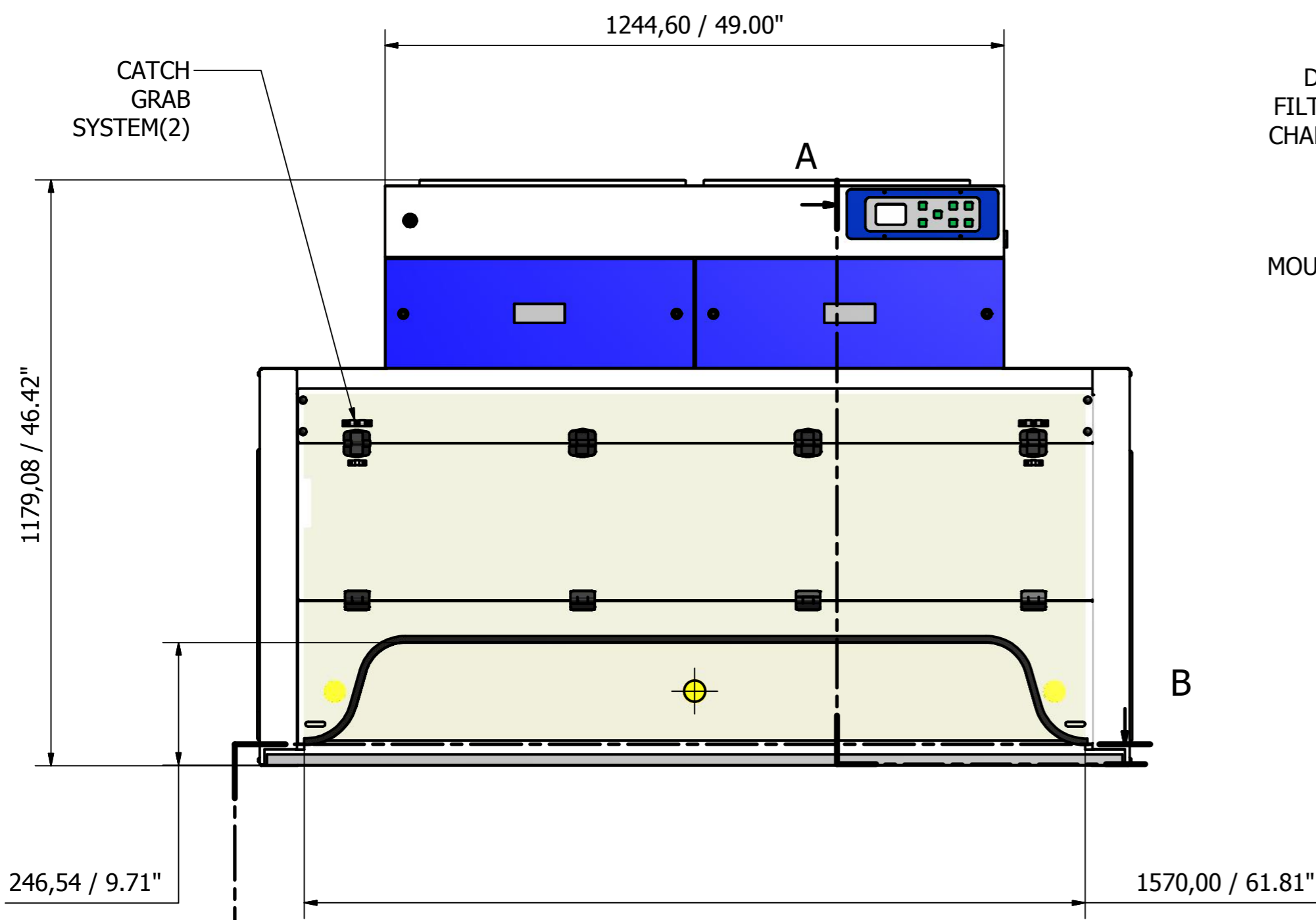

- NOTES:**
- STANDARD ON ALL UNITS:
 - 1.0 CONSTRUCTION: EPOXY COATED MILD STEEL SIDES PANELS AND HEAD UNIT.
 - 2.0 FRONT, SIDES AND BACK PANELS MADE ON CLEAR ACRYLIC OF 1/4".
 - 3.0 TEMPERED GLASSES ON SIDE PANELS.
 - 4.0 CENTRIFUGAL FANS.
 - 5.0 POWER SUPPLY 110V 60Hz.
 - 6.0 MAIN SWITCH ON/OFF.
 - 7.0 MONITORING, LOW AIRFLOW.

Designed by CFG	Checked by	Approved by	Date 3/22/2011	Date
AIR SCIENCE USA		PURAIR 30UL DUCTLESS FUME HOOD		
Purair30.2Fan.Assem		Edition 1	Sheet 1 / 1	