

REVISION HISTORY				
ZONE	REV	DESCRIPTION	DATE	APPROVED
SIDE PANELS	1	TEMPERED GLASSES	5/15/2017	P CH

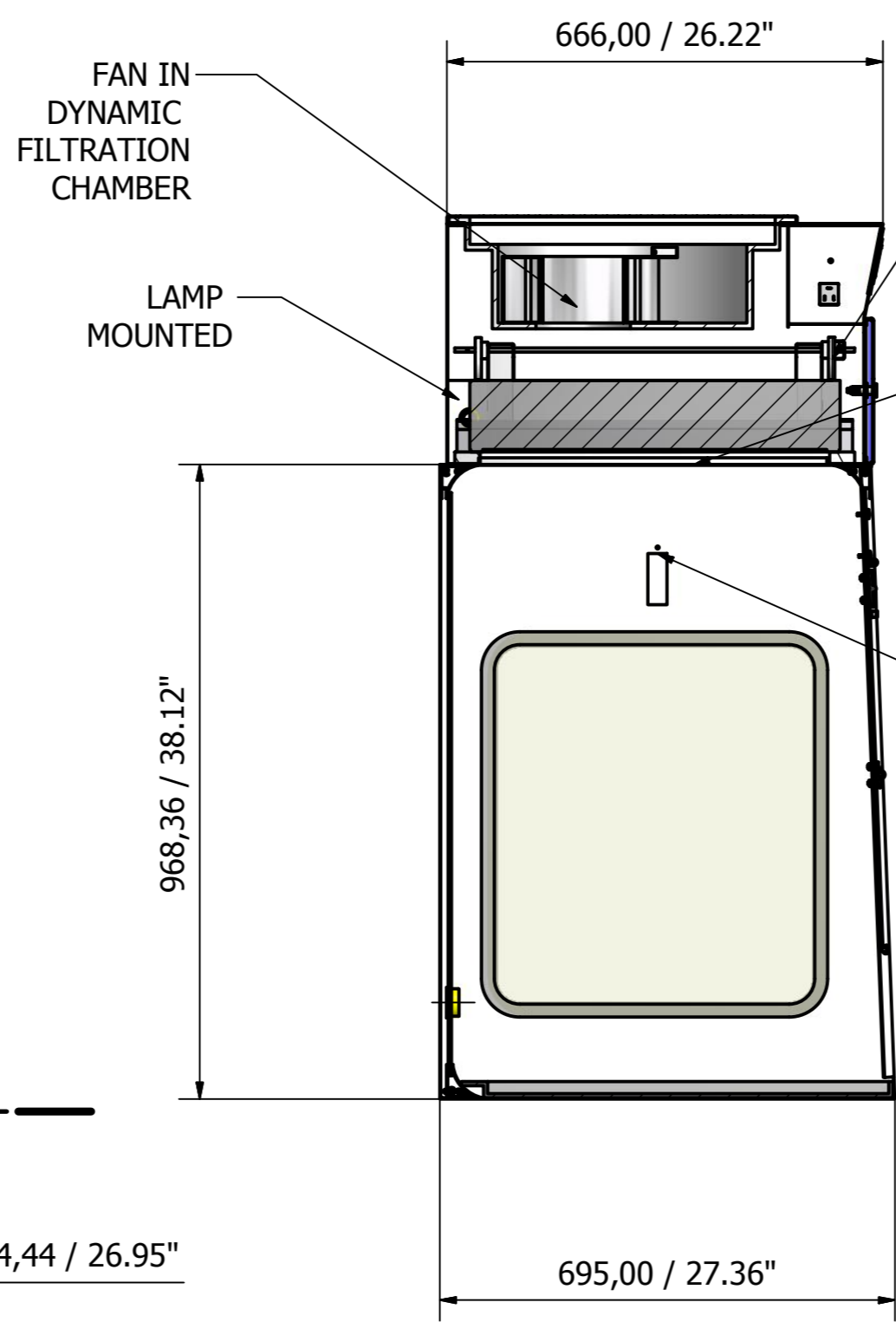

- NOTES:**
- STANDARD ON ALL UNITS:
  - 1.0 CONSTRUCTION: EPOXY COATED MILD STEEL SIDES PANELS AND HEAD UNIT.
  - 2.0 FRONT AND BACK PANELS MADE ON CLEAR ACRYLIC OF 1/4".
  - 3.0 TEMPERED GLASSES ON SIDE PANELS.
  - 4.0 CENTRIFUGAL FAN.
  - 5.0 POWER SUPPLY 110V 60Hz.
  - 6.0 MAIN SWITCH ON/OFF.
  - 7.0 MONITORING, LOW AIRFLOW

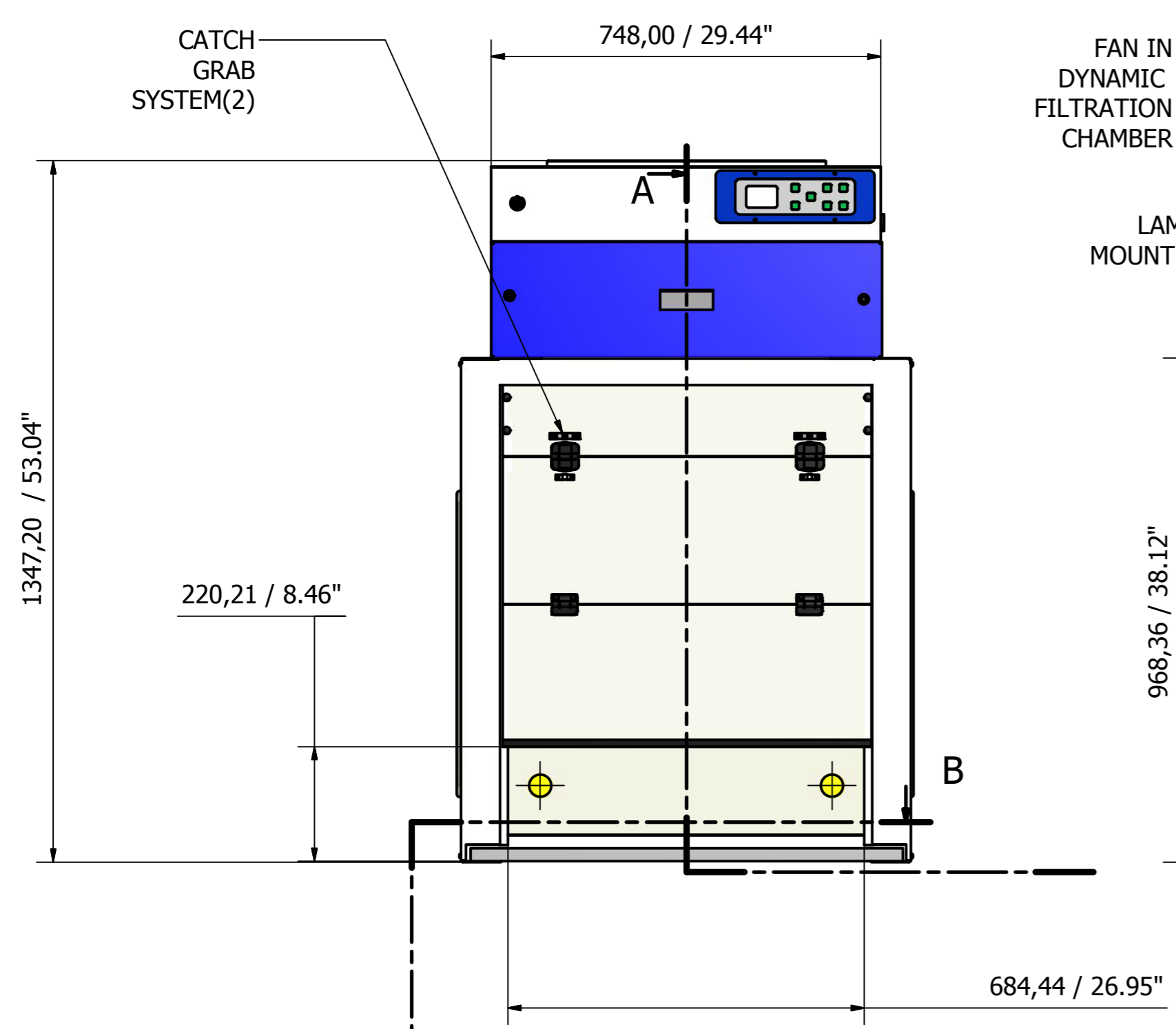
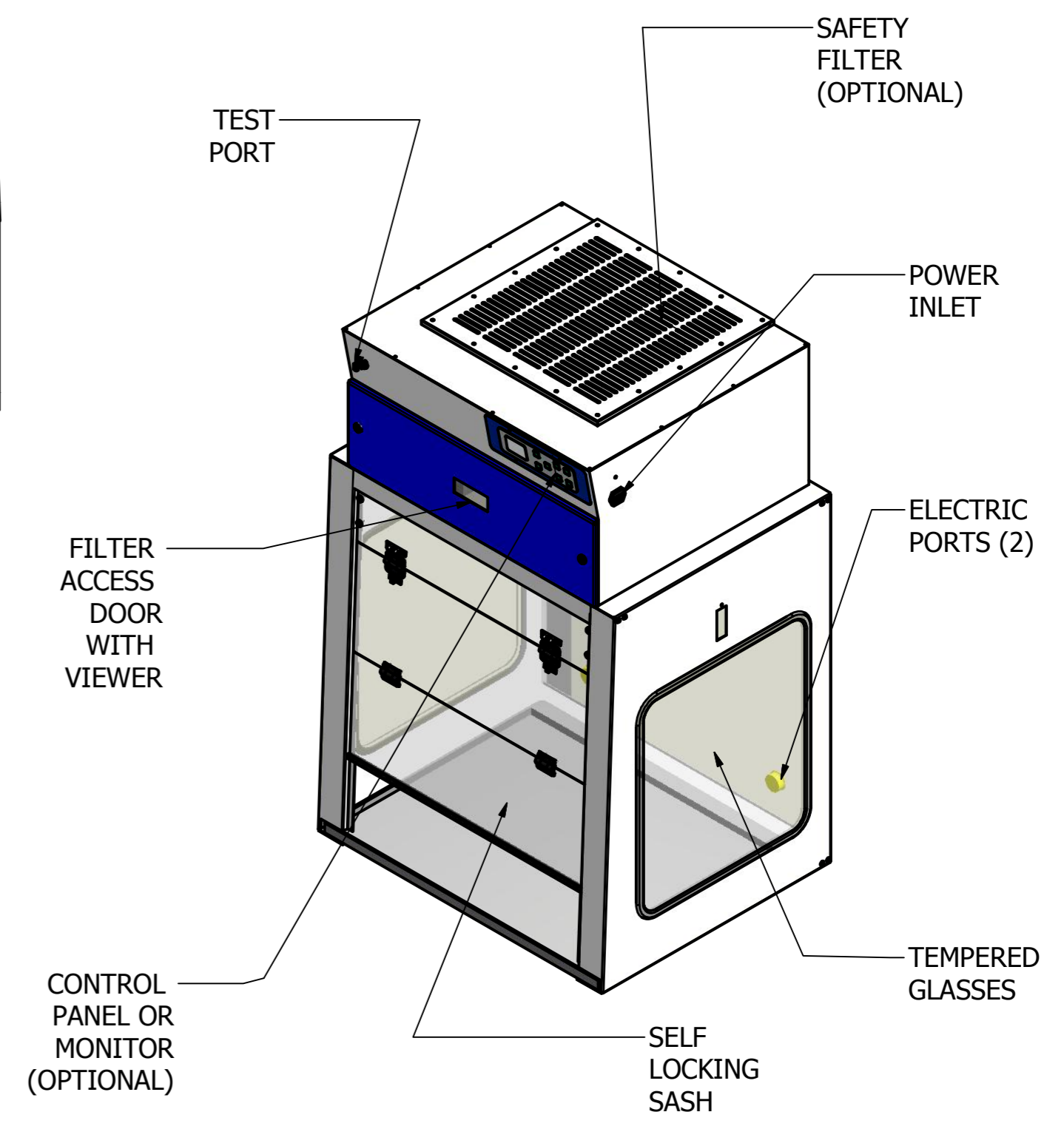
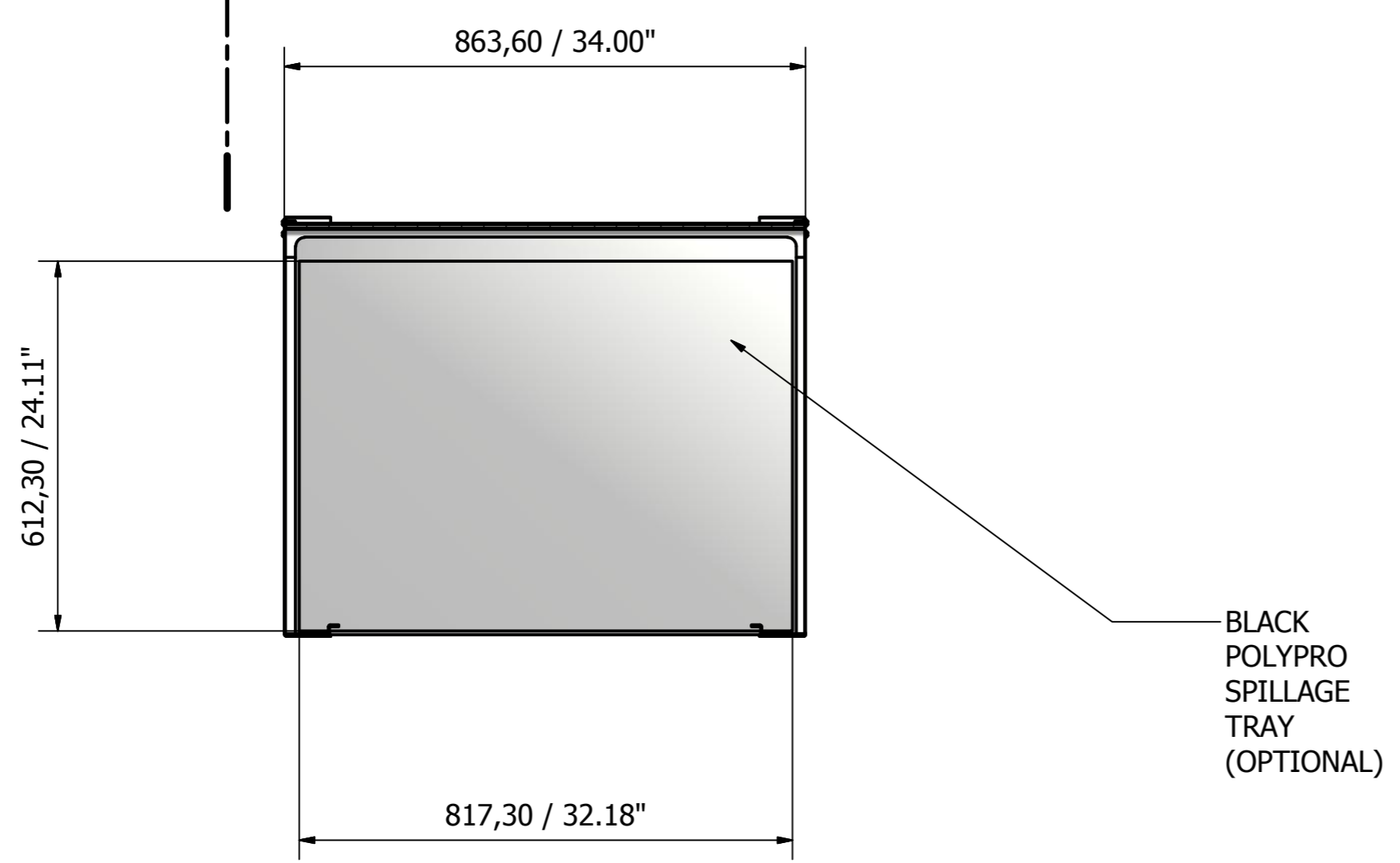

Designed by CFG	Checked by	Approved by	Date 9/21/2012	Date
AIR SCIENCE USA			PURAIR 10XTL.UL DUCTLESS FUME HOOD	
			Purair10XTXL-UL.Assem	Sheet 1 / 1