

REVISION HISTORY				
ZONE	REV	DESCRIPTION	DATE	APPROVED
WORK ZONE	1	SS WORK SURFACE 40 MM HIGH	1/10/2010	P CH
WORK ZONE	2	SS WORK SURFACE 60 MM HIGH	10/7/2016	P CH
STAND BASE	3	NEW MODEL CART OR BASE STAND	4/11/2017	P CH
UNIT	4	UPDATE METAL UNIT	4/18/2019	P CH

NOTES :

- 1.0 CUSTOMER
- 2.0 SUBMIT DRAWING FOR APPROVAL.
- 3.0 STANDARD FEATURES INCLUDED.
- 3.1 CONSTRUCTION, EPOXY COATED MILD STEEL.
- 3.2 STAINLESS STEEL WORK SURFACE .
- 3.3 SIDES PANELS MADE IN TEMPERED GLASSES.
- 3.4 CANFIL-FARR ULPA MAIN FILTER.
- 3.5 INTERNAL LIGHTNING.
- 3.6 INTERNAL GFCI OUTLET.
- 3.7 FAN SPEED CONTROL.
- 3.8 OPTIONAL; BASE STAND OR MOVIL CART.
- 3.9 CONTROL PANEL: FAN'S ON/OFF, MINIHELIC ULPA PRESSURE GAUGE, GFCI OUTLET, AND LIGHTS SWITCHES.
- 4.0 EBMPAPST ROTOR BLOWER.
- 5.0 POWER INLET 120 V 60 HZ OR 220 V 50 HZ.
- 6.0 OPTIONAL; HANGING BAR WITH "S" HOOKS.
- 7.0 W/O

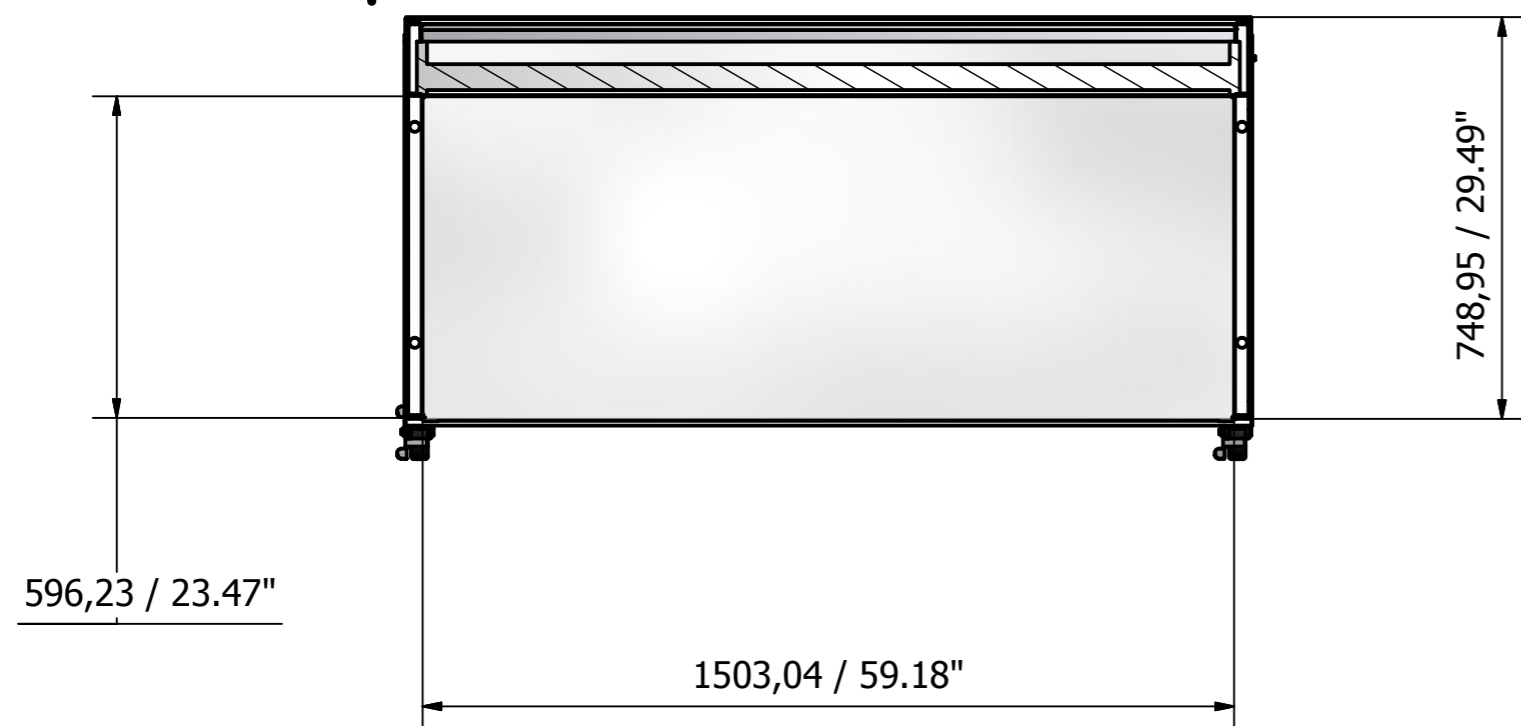
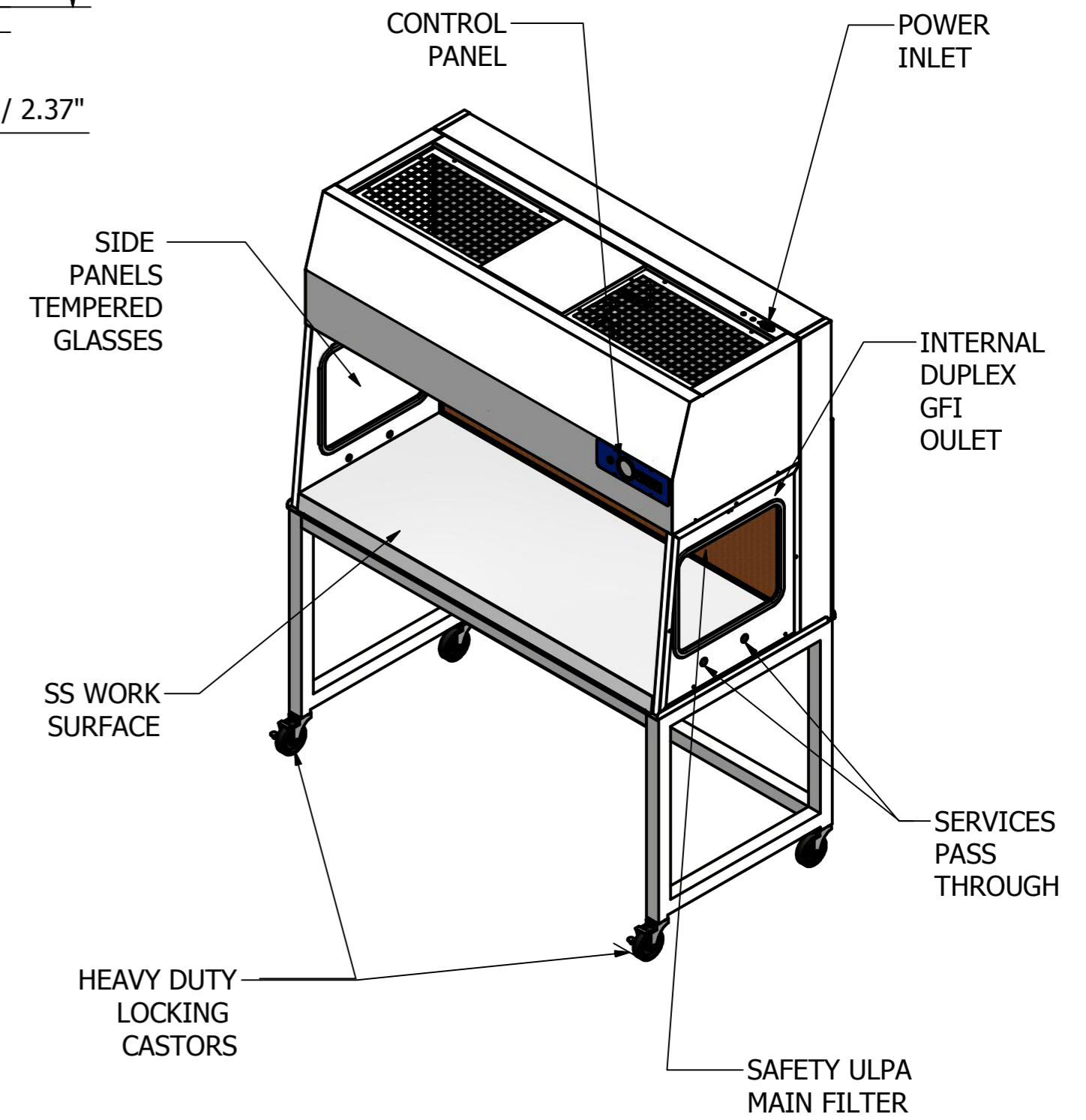
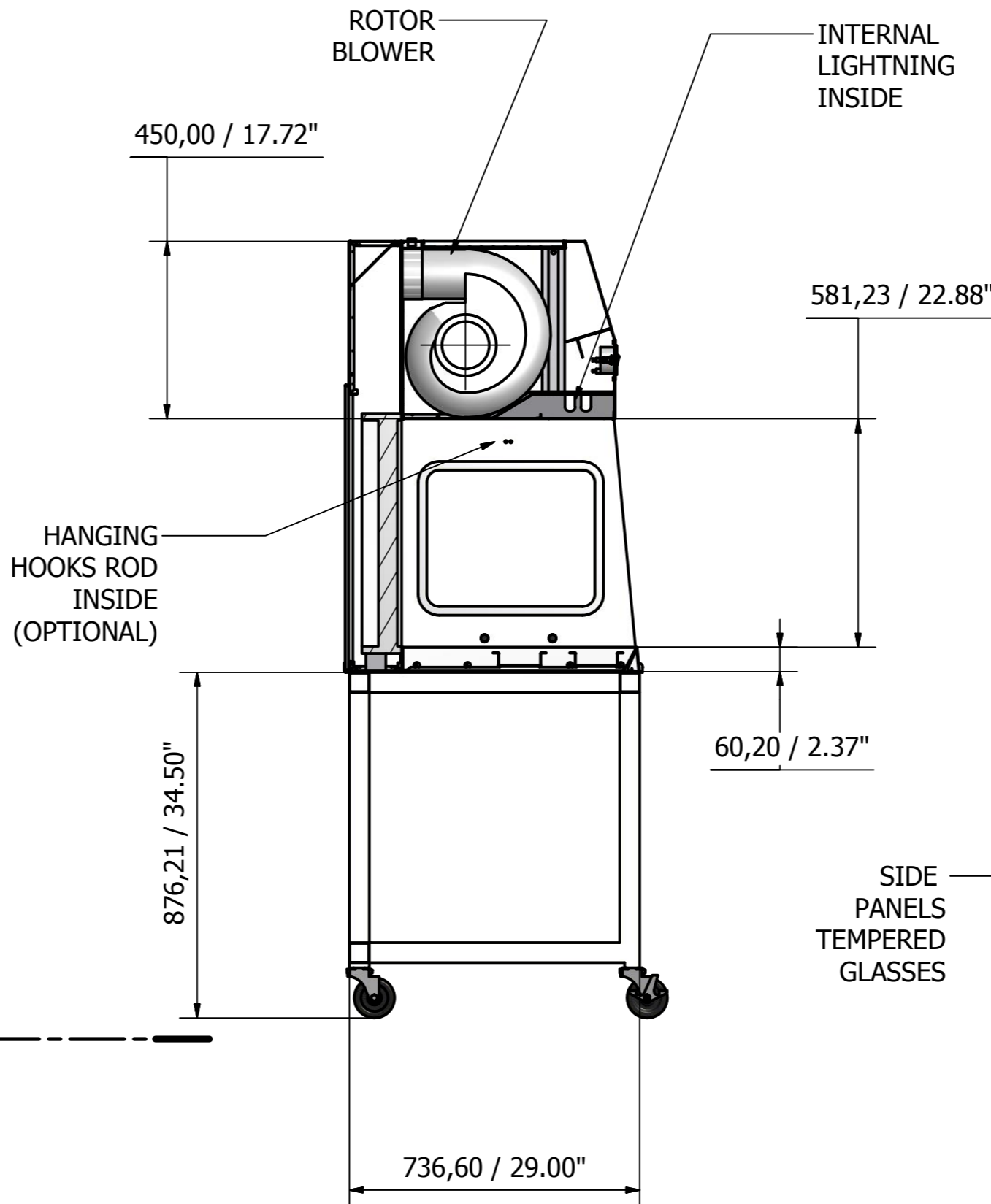
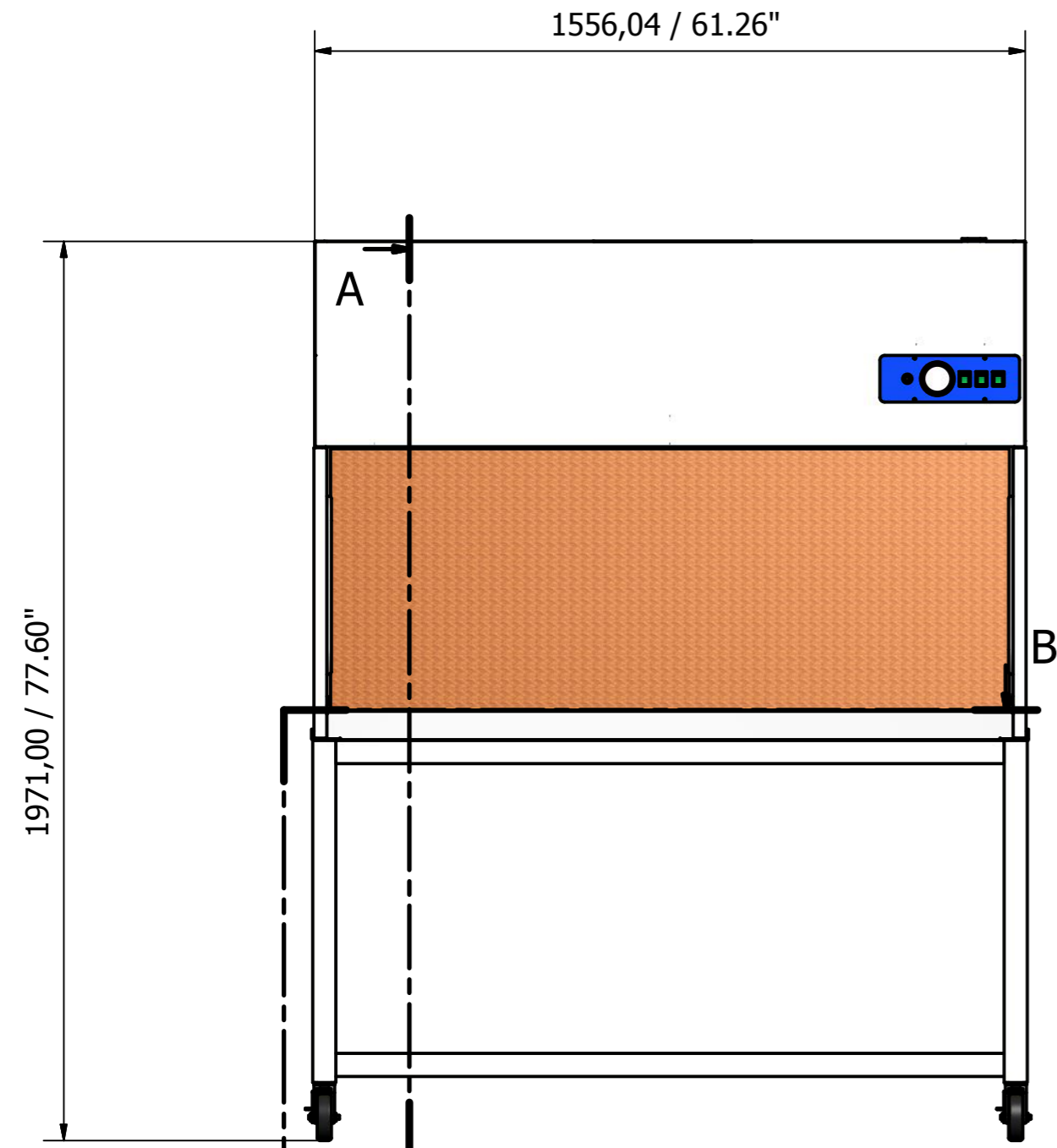

Designed by CFG	Checked by	Approved by	Date	Date 10/4/2011
AIR SCIENCE USA		HLF-60 HORIZONTAL LAMINAR FLOW		
HLF-60.GAssem			Edition 4	Sheet 1 / 1