

REVISION HISTORY				
ZONE	REV	DESCRIPTION	DATE	APPROVED
CHAMBER	1	METAL SHELVES	1/02/2013	P CH
BOTTOM LEVEL	2	POWER CONNECTION	6/07/2014	P CH
WORK SURFACE	3	PC-HUMIDIFIER	7/14/2015	P CH
WORK SURFACE	4	HONEYWELL HUMIDIFIER	1/04/2016	P CH

SAFEFUME AUTOMATIC CYANOACRYLATE FUMING CHAMBER

- NOTES :**
- 1.0 CUSTOMER:
 - 2.0 SUBMIT DRAWINGS FOR APPROVAL.
 - 3.0 STANDARD FEATURES INCLUDE:
 - 3.1 CABINET BUILT WITH 3/8" WHITE POLYPROPYLENE SEAMLESS, NON-POROUS WATERTIGHT INSIDE, THERMALLY FUSE.
 - 3.2 FRONT METAL DOOR WITH TEMPERED GLASS.
 - 3.3 CARBON MAIN FILTER.
 - 3.4 POWER SUPPLY 120 V 60 HZ.
 - 3.5 HOT PLATE ACCELERATOR.
 - 3.6 NEBULIZER / HUMIDIFIER.
 - 3.7 STANDARD ACCESORIES APPLIED.
 - 3.8 MICROPROCESSOR SCREEN TOUCH PAD CONTROL PANEL.
 - 4.0 W/O

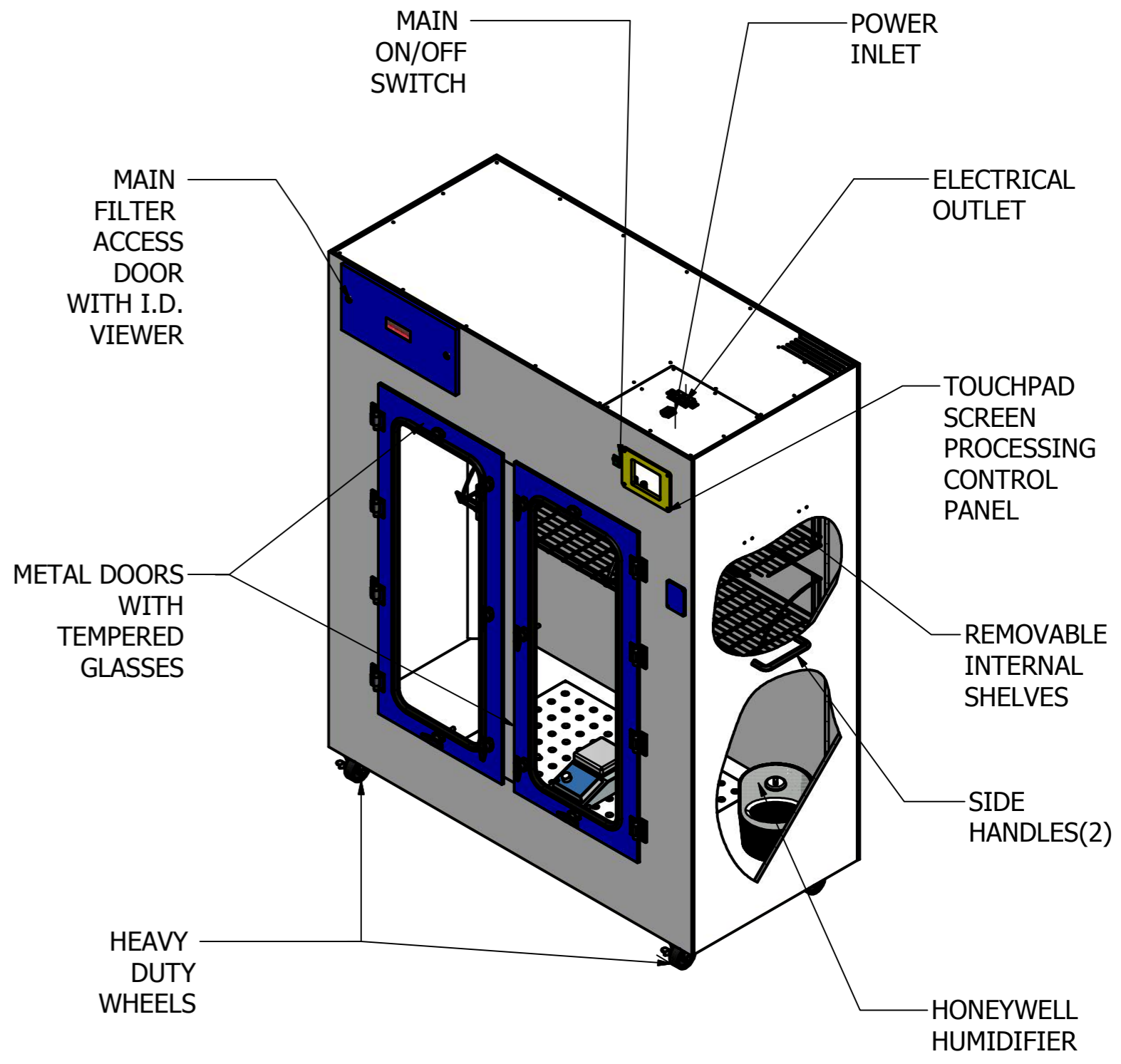
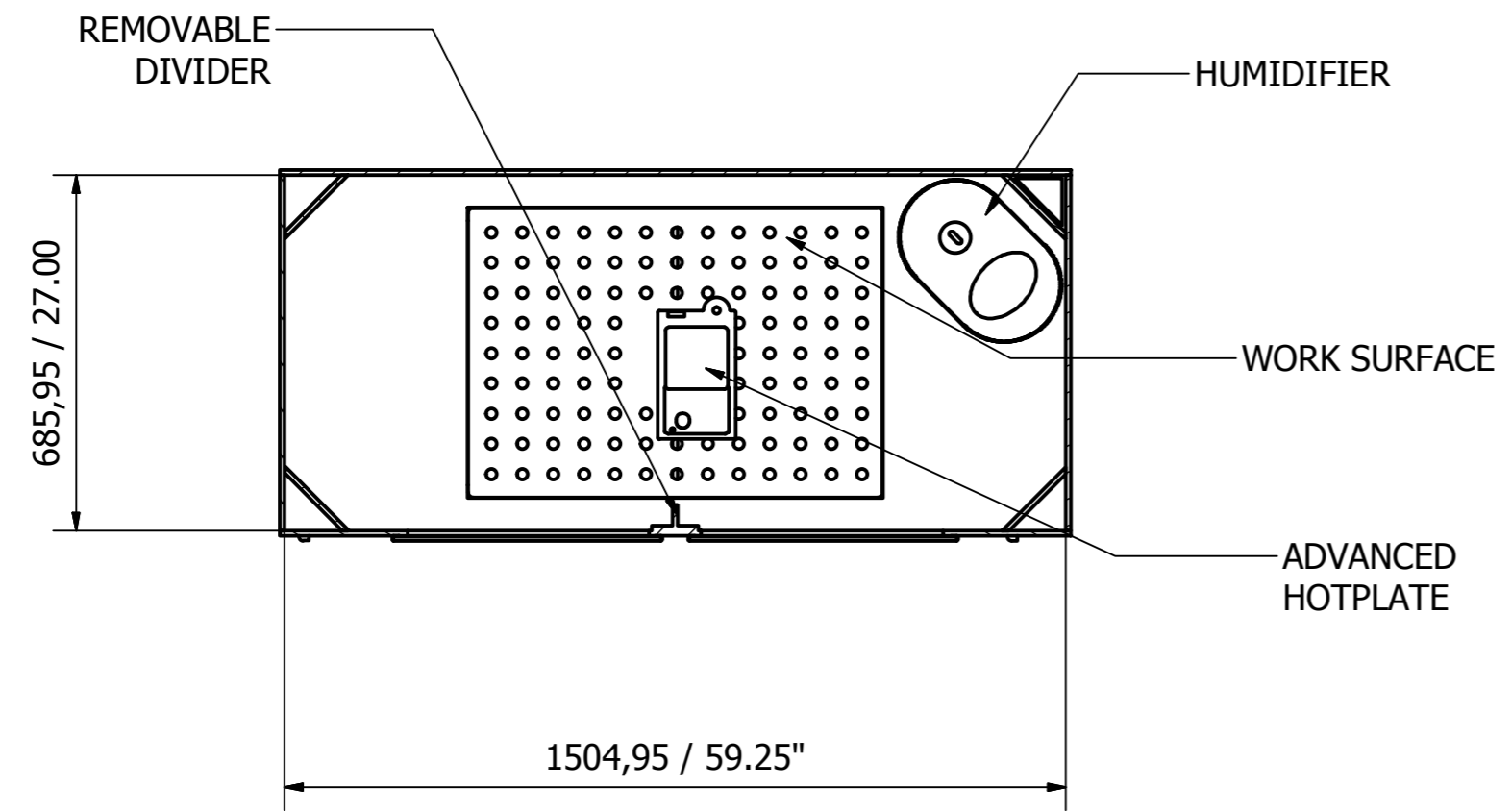
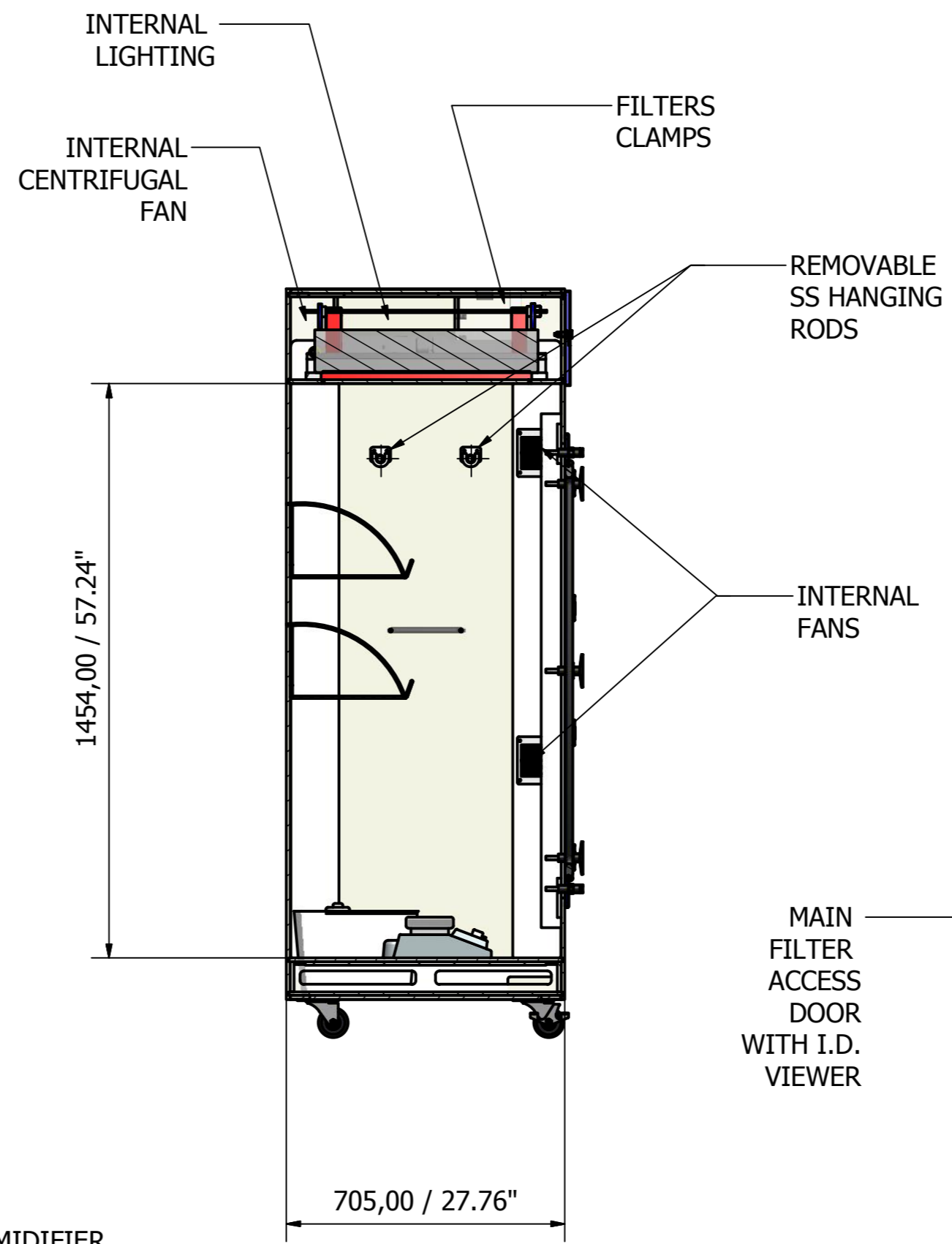
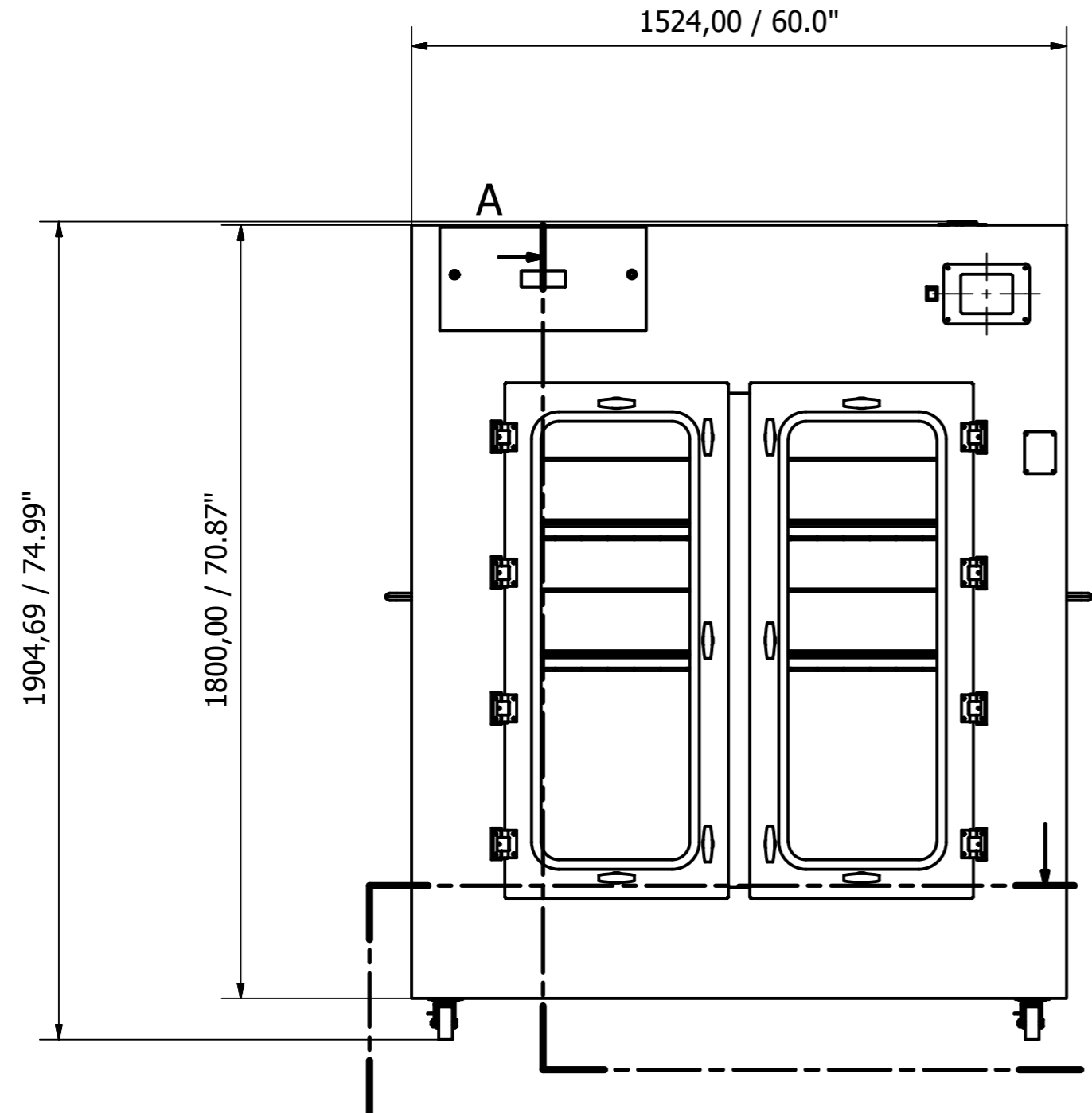

B-B (1 : 14)

A-A (1 : 14)

Designed by CFG	Checked by	Approved by	Date 4/30/2012	Date
AIR SCIENCE USA		CA60T FUMING CHAMBER		
		CA60R12.1800T-GAssem	Edition 4	Sheet 1 / 1