

REVISION HISTORY				
ZONE	REV	DESCRIPTION	DATE	APPROVED
CHAMBER	1	METAL SHELVES	1/02/2013	P CH
BOTTOM LEVEL	2	POWER CONNECTION	6/07/2014	P CH
WORK SURFACE	3	PC-HUMIDIFIER	7/14/2015	P CH
WORK SURFACE	4	HONEYWELL HUMIDIFIER	1/04/2016	P CH

# SAFEFUME AUTOMATIC CYANOACRYLATE FUMING CHAMBER

NOTES :  
1.0 CUSTOMER:

- 2.0 SUBMIT DRAWINGS FOR APPROVAL.
- 3.0 STANDARD FEATURES INCLUDE:
- 3.1 CABINET BUILT WITH 3/8" WHITE POLYPROPYLENE SEAMLESS, NON-POROUS WATERTIGHT INSIDE, THERMALLY FUSE.
- 3.2 FRONT METAL DOOR WITH TEMPERED GLASS.
- 3.3 CARBON MAIN FILTER.
- 3.4 POWER SUPPLY 120 V 60 HZ.
- 3.5 HOT PLATE ACCELERATOR.
- 3.6 NEBULIZER / HUMIDIFIER.
- 3.7 STANDARD ACCESSORIES APPLIED.
- 3.8 MICROPROCESSOR SCREEN TOUCH PAD CONTROL PANEL.
- 4.0 W/O

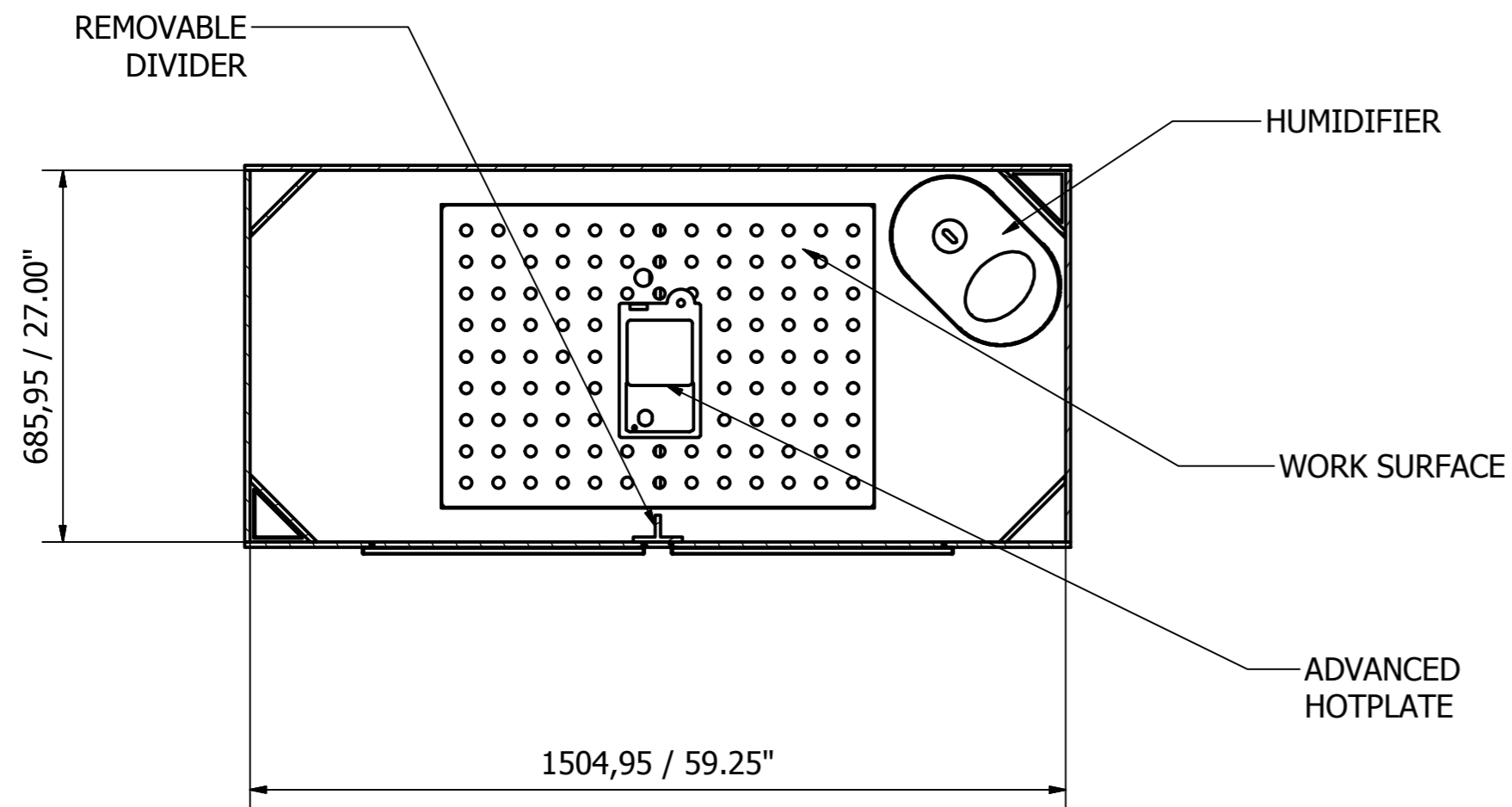
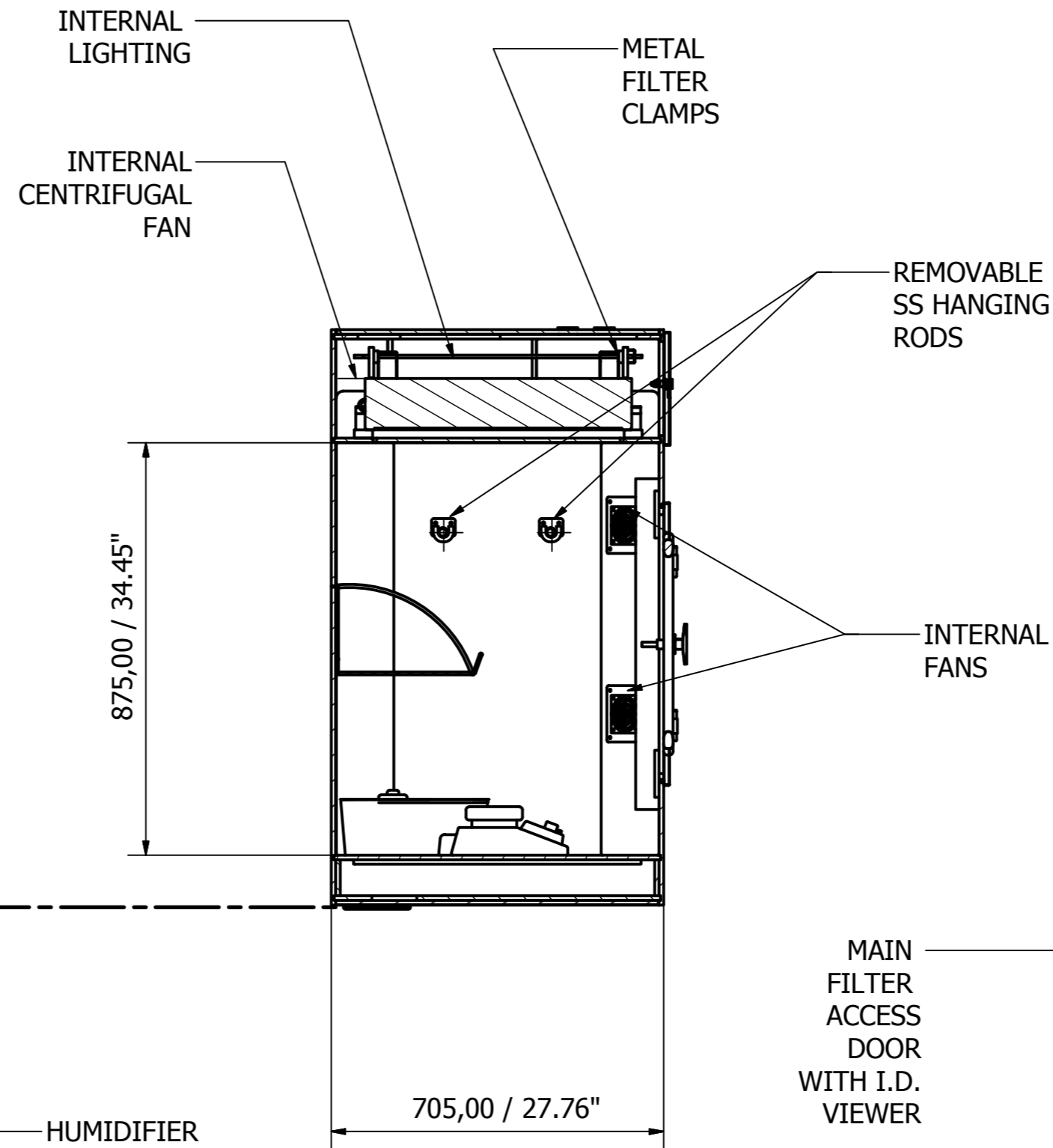
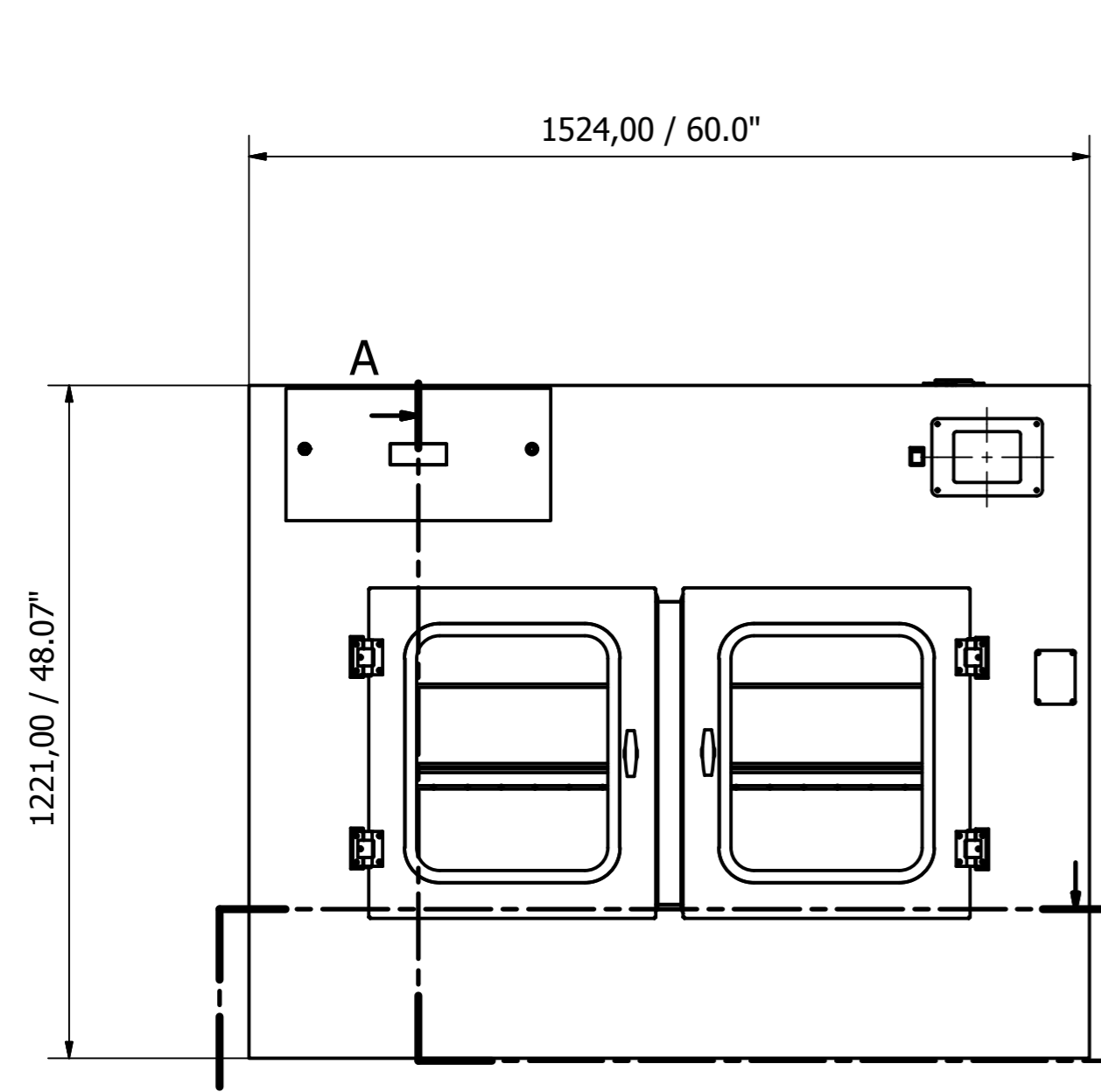

A-A ( 1 : 12 )

B-B ( 1 : 12 )

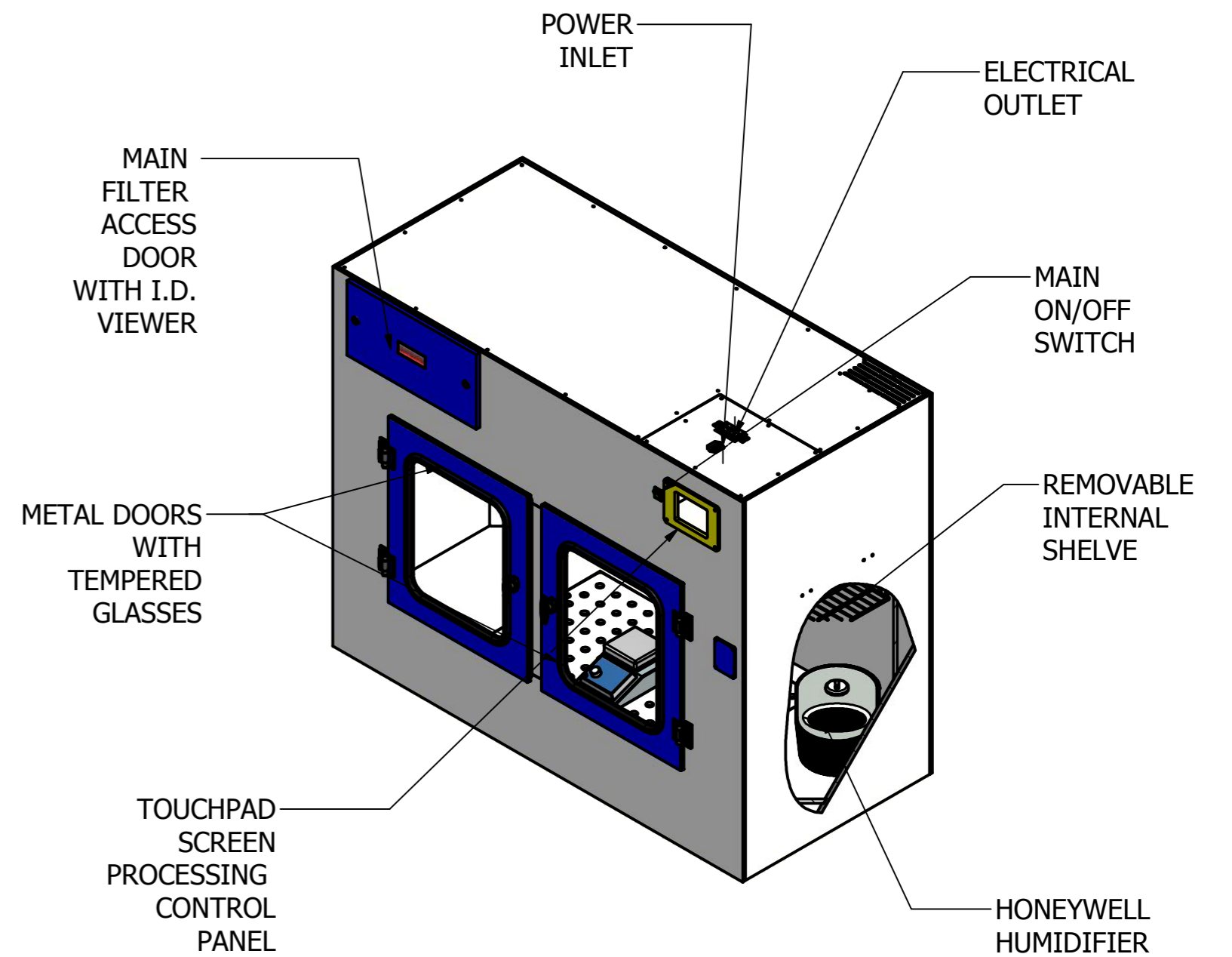

Designed by CFG	Checked by	Approved by	Date 4/25/2012	Date
AIR SCIENCE USA		CA60S FUMING CHAMBER		
		CA60SR12-GAssem	Edition 4	Sheet 1 / 1